

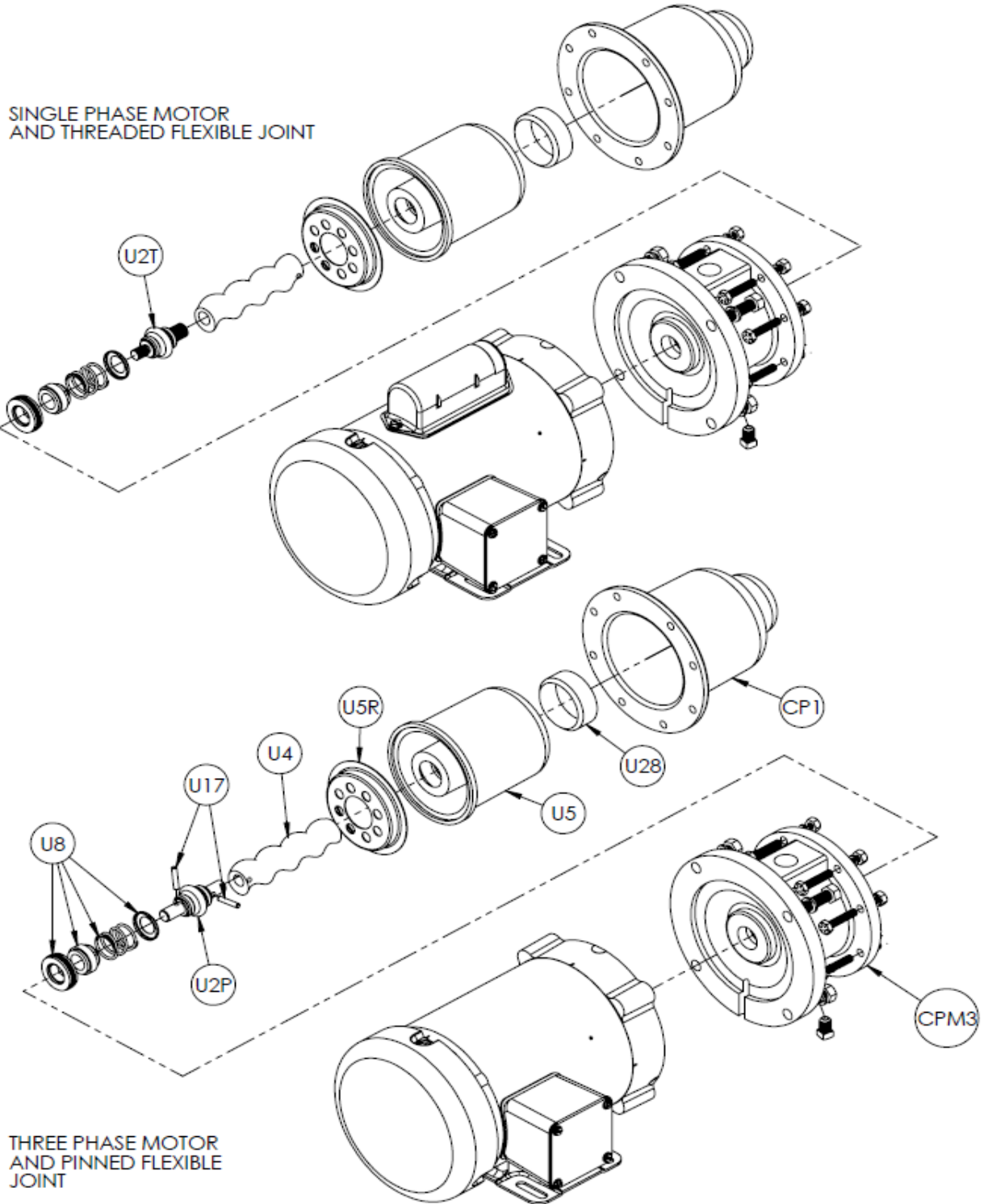

## Continental Progressive Cavity Pump CP Model CPM22 Close-Coupled Pump Driven with a Continental Spec. Motor



### Continental Pump Company

29425 State Hwy B | Warrenton, Missouri 63383 | Tel: 636-456-6006 | Fax: 636-456-4337 | Email: sales@con-pump.com  
Visit us at: [www.continentalultrapumps.com](http://www.continentalultrapumps.com)



## CPM Model Number Nomenclature:

Materials used in the pumps are based on the fluid to be handled and are indicated in the model number nomenclature.

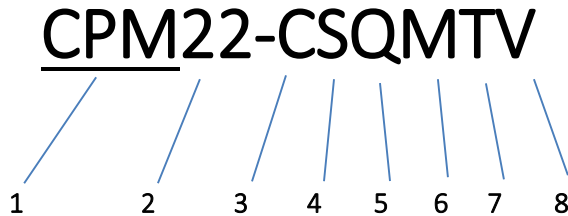

- (1): Indicates the pump model designation (CP, CPM, CPML Model)
- (2): Indicates the pump frame size designation
- (3): Indicates the pump body casting material
- (4): Indicates the rotor material
- (5): Indicates the stator material
- (6): Indicates seal type: Mechanical Seal or Packed Seal (For Mechanical use M, for Packed use D)
- (7): Indicates if the Drive Shaft, Flex Joint, and Rotor is Pinned or Threaded. (For pinned use P, for threaded use T)
- (8): Indicates if the pump has vertical suction housing. If horizontal is preferred no designation will be used.

### Material of Construction

Continental Part Description	Continental Letter Designation	Part Materials
Pump Body	C	Cast Iron
	S	316 Stainless Steel (CF8M)
Rotor	D	Chrome Plated Alloy Steel
	S	Chrome Plated Stainless Steel
Stator	Q	Buna Nitrile
	B	EPDM
	F	Viton®
Seal Type	M	Mechanical Seal
	D	Packing Gland

Mechanical Seal and Packed Seal options are available for all frame sizes (15, 22, 33, 44, 56, and 67).

The Pinned Drive Shaft, Flex Joint, and Rotor option is also available for all frame sizes. The Threaded option is available only in frame sizes 15, 22, 33, 44, and 56; Size 67 has pinned option only.

### Continental Pump Company







29425 State Hwy B | Warrenton, Missouri 63383 | Tel: 636-456-6006 | Fax: 636-456-4337 | Email: [sales@con-pump.com](mailto:sales@con-pump.com)  
 Visit us at: [www.continentalultrapumps.com](http://www.continentalultrapumps.com)



## CPM Pump

### Replacement Parts

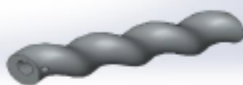
for CPM22 Close-Coupled Pump with Continental Spec. Motor

Part	Part Name	Continental Pump Part Number	For Continental Pump Model
	Suction Body	CP1-15C CP1-15S	CPM22
	Suction Body, Vertical	CPV1-15C CPV1-15S	CPM22
	Discharge Housing with 1/8" NPT Drain Plug	CPM3-15C	CPM22
	Flexible Joint, Pinned	U2-15PQS U2-15PBS U2-15PFS	CPM22
	Flexible Joint, Threaded	U2-15TQS U2-15TBS U2-15TFS	CPM22
	Rotor, Pinned & Threaded	U4-22PTS	CPM22
	Stator	U5-22Q U5-22B U5-22F	CPM22
	Stator Barrier (Optional)	U5R-15S	CPM22

### Continental Pump Company

29425 State Hwy B | Warrenton, Missouri 63383 | Tel: 636-456-6006 | Fax: 636-456-4337 | Email: sales@con-pump.com  
Visit us at: [www.continentalultrapumps.com](http://www.continentalultrapumps.com)



Part	Part Name	Continental Pump Part Number	For Continental Pump Model
	Mechanical Seal	U8-15Q U8-15B U8-15F	CPM22
	Mechanical Seal, Abrasive Resistant (Optional)	U8-15Q A/R U8-15B A/R U8-15F A/R	CPM22
	1/8" NPT Drain Plug for Discharge Housing	U12-15CS U12-15S	CPM22
	Roll Pins (2 Required)	U17-15S	CPM22
	Stator Ring	U28-15S	CPM22
	Single Phase Motor, .5 HP/1725 RPM for Threaded Pump Only	34G405-5593	CPM22
	Three Phase Motor, .5 HP/1725 RPM for Pinned Pump Only	34G50-872	CPM22

**Continental Pump Company**



29425 State Hwy B | Warrenton, Missouri 63383 | Tel: 636-456-6006 | Fax: 636-456-4337 | Email: sales@con-pump.com  
 Visit us at: [www.continentalultrapumps.com](http://www.continentalultrapumps.com)



## CPM Pump

### Replacement Kits

for CPM22 Close-Coupled Pump with Continental Spec. Motor

Part	Part Name	Continental Pump Part Number	For Continental Pump Model
	<b>Pinned Rebuild Kit:</b> Includes: QTY 1: Flex Joint, Rotor, Stator, Mechanical Seal; Qty 2: Roll Pins	CP22K-PQS CP22K-PBS CP22K-PFS	CPM22
	<b>Pinned Rebuild Kit with A/R Seal:</b> Includes: QTY 1: Flex Joint, Rotor, Stator, Mechanical Seal-Abrasive Resistant; Qty 2: Roll Pins	CP22K-PQS A/R CP22K-PBS A/R CP22K-PFS A/R	CPM22
	<b>Threaded Rebuild Kit:</b> Includes: QTY 1: Flex Joint, Rotor, Stator, Mechanical Seal	CP22K-TQS CP22K-TBS CP22K-TFS	CPM22
	<b>Threaded Rebuild Kit with A/R Seal:</b> Includes: QTY 1: Flex Joint, Rotor, Stator, Mechanical Seal-Abrasive Resistant	CP22K-TQS A/R CP22K-TBS A/R CP22K-TFS A/R	CPM22
	<b>Bolt Kit:</b> Includes Qty 8: Pump Body Bolts, Washers & Nuts. Qty 4: C-Face Motor Bolts & Washers. Qty 1: 1/8" NPT Drain Plug	U10-15MC	CPM22

### Continental Pump Company

29425 State Hwy B | Warrenton, Missouri 63383 | Tel: 636-456-6006 | Fax: 636-456-4337 | Email: sales@con-pump.com  
 Visit us at: [www.continentalultrapumps.com](http://www.continentalultrapumps.com)



## Materials of Construction

All Continental Pump casting materials are Class 40# grey cast iron and CF8M (316) stainless steel. The best metal for your application would depend on how corrosive your liquid is. We offer an epoxy coating for an additional charge and can be applied to the suction housing and discharge. The epoxy seals the cast iron from the material being pumped.

Stators are available in 3 types of elastomers. The rubber materials are: Buna Nitrile, EPDM and Viton®. The rubber that is best for your application depends on what liquid you are pumping and at what temperature, as it plays a vital role in which to select.

The rotors are available in Chrome Plated Stainless Steel.

Abrasive Resistance Mechanical Seals are a great upgrade for your more abrasive applications. By adding a Stator Barrier, which is recommended in any negative suction and/or vacuum application to help protect the stator. There are lots of variables to take in consideration to know if this is right for your application. Contact us with your application information to see if this is for you.

**Looking for simplicity?** We offer complete Progressive Cavity Pump Units. They are constructed on a steel base to fit your specific application needs. The Unit consists of a Pump, a Steel Base & Guard, a Gear Reducer and Motor. Also available are Belt Drive Units, Gas or Diesel Engines, and many other base options.

**Space Challenged?** If you are needing a different arrangement from traditional piping, we have vertical suction housings available in the CP Model.

**Don't need a complete pumping unit but looking for drive options?** We can still help, whether attached to a pump or sold separately we can supply you with VFD's, Motors and Bases.

### **Continental Pump Company**

29425 State Hwy B | Warrenton, Missouri 63383 | Tel: 636-456-6006 | Fax: 636-456-4337 | Email: [sales@con-pump.com](mailto:sales@con-pump.com)  
Visit us at: [www.continentalultrapumps.com](http://www.continentalultrapumps.com)