

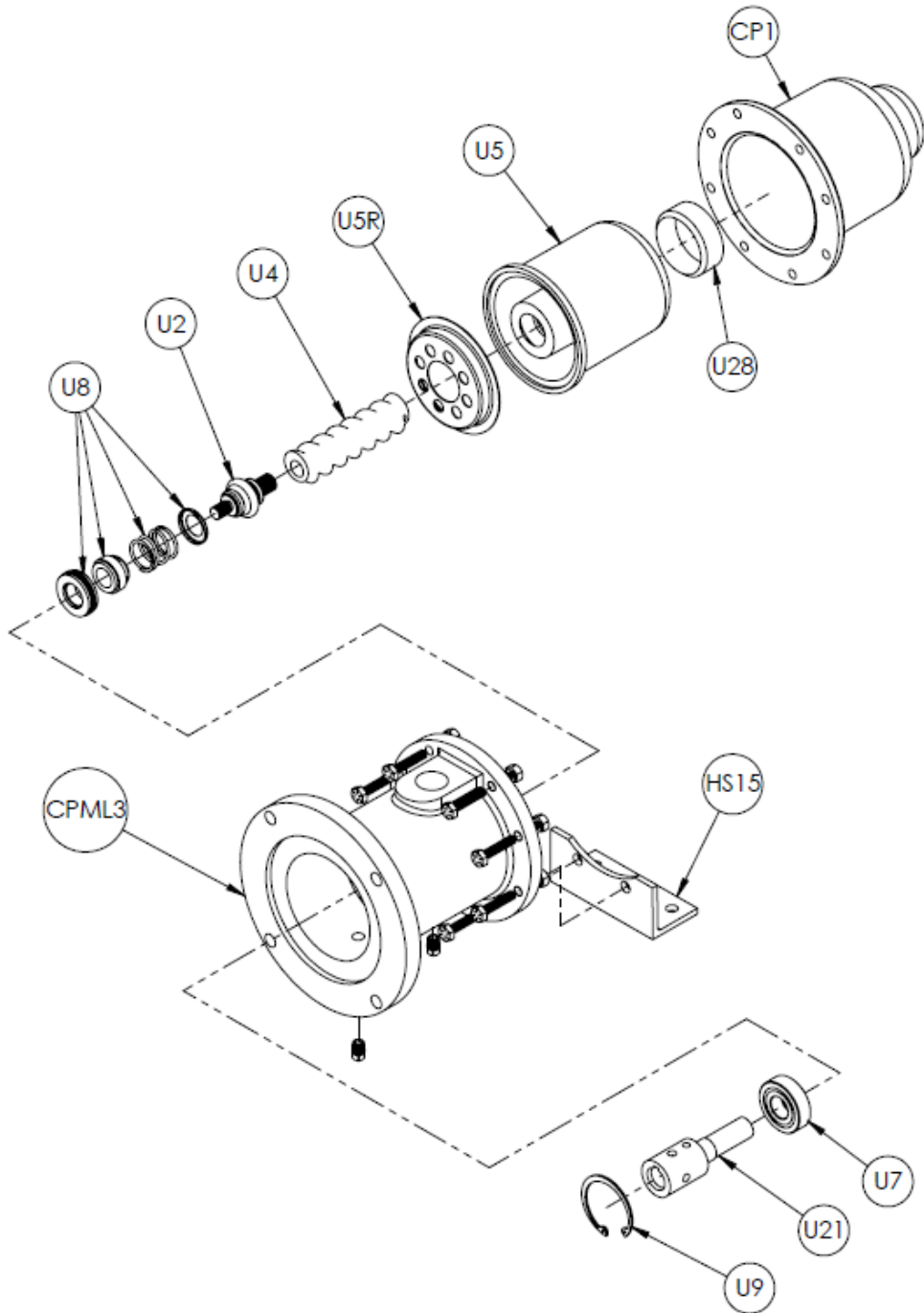

Continental Progressive Cavity Pump CP Model
CPML15 Close-Coupled Pump Driven with a Standard Motor



Pump bolts to any Nema Frame 56 C-Face motor with feet.

Continental Pump Company

29425 State Hwy B | Warrenton, Missouri 63383 | Tel: 636-456-6006 | Fax: 636-456-4337 | Email: sales@con-pump.com
Visit us at: www.continentalultrapumps.com



CP Model Number Nomenclature:

Materials used in the pumps are based on the fluid to be handled and are indicated in the model number nomenclature.

CPML15-CSQMTV

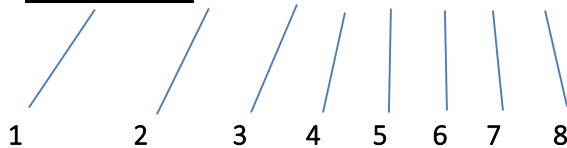

- (1): Indicates the pump model designation (CP, CPM, CPML Model)
- (2): Indicates the pump frame size designation
- (3): Indicates the pump body casting material
- (4): Indicates the rotor material
- (5): Indicates the stator material
- (6): Indicates seal type: Mechanical Seal
- (7): Indicates that the Drive Shaft, Flex Joint, and Rotor is Threaded. (For pinned use P, for threaded use T)
- (8): Indicates if the pump has vertical suction housing. If horizontal is preferred no designation will be used.

Material of Construction

Continental Part Description	Continental Letter Designation	Part Materials
Pump Body	C	Cast Iron
	S	316 Stainless Steel (CF8M)
Rotor	D	Chrome Plated Alloy Steel
	S	Chrome Plated Stainless Steel
Stator	Q	Buna Nitrile
	B	EPDM
	F	Viton®
Seal Type	M	Mechanical Seal
	D	Packing Gland

Mechanical Seal option is available for all frame sizes (15, 22, 33, 44, 56, and 67).

The Threaded Drive Shaft, Flex Joint, and Rotor option is available only in frame sizes 15, 22, 33, 44, and 56; Size 67 has pinned option only.

Continental Pump Company

29425 State Hwy B | Warrenton, Missouri 63383 | Tel: 636-456-6006 | Fax: 636-456-4337 | Email: sales@con-pump.com
Visit us at: www.continentalultrapumps.com



CPML Pump

Replacement Parts

for CPML15 Close-Coupled Pump Driven with a Standard Motor

Part	Part Name	Continental Pump Part Number	For Continental Pump Model
	Suction Body	CP1-15C CP1-15S	CPML15
	Suction Body, Vertical	CPV1-15C CPV1-15S	CPML15
	Discharge Housing with 1/8" NPT Drain Plug	CPML3-15C CPML3-15S	CPML15
	Flexible Joint, Threaded	U2-15TQS U2-15TBS U2-15TFS	CPML15
	Rotor, Pinned & Threaded	U4-15PTS	CPML15
	Stator	U5-15Q U5-15B U5-15F	CPML15
	Stator Barrier (Optional)	U5R-15S	CPML15
	Ball Bearing	U7-15	CPML15

Continental Pump Company

29425 State Hwy B | Warrenton, Missouri 63383 | Tel: 636-456-6006 | Fax: 636-456-4337 | Email: sales@con-pump.com
Visit us at: www.continentalultrapumps.com



Part	Part Name	Continental Pump Part Number	For Continental Pump Model
	Mechanical Seal	U8-15Q U8-15B U8-15F	CPML15
	Mechanical Seal, Abrasive Resistant (Optional)	U8-15Q A/R U8-15B A/R U8-15F A/R	CPML15
	Retaining Ring	U9-15	CPML15
	1/8" NPT Drain Plug for Discharge Housing	U12-15C U12-15S	CPML15
	Motor Coupling	U21-15S	CPML15
	Stator Ring	U28-15S	CPML15
	Housing Support	CPML15-HS	CPML15

Motor Options: The CPML pump can be bolted to any NEMA Frame 56 C-Face Motor with Feet. The minimum horsepower requirement for this Pump is a 1/2 HP motor.

Continental Pump Company





29425 State Hwy B | Warrenton, Missouri 63383 | Tel: 636-456-6006 | Fax: 636-456-4337 | Email: sales@con-pump.com
Visit us at: www.continentalultrapumps.com

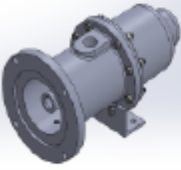

CPML Pump

Replacement Kits

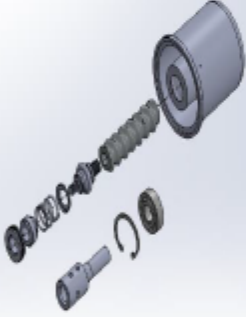
for CPML15 Close-Coupled Pump Driven with a Standard Motor

Part	Part Name	Continental Pump Part Number	For Continental Pump Model
	<u>Pump End Kit*</u> : Includes CPML Cast Iron Pump less Motor	CPML15K-CSQMT CPML15K-CSBMT CPML15K-CSFMT	CPML15
	<u>Pump End Kit*</u> : Includes CPML Stainless Steel Pump less Motor	CPML15K-SSQMT CPML15K-SSBMT CPML15K-SSFMT	CPML15
	<u>Vertical Pump End Kit*</u> : Includes CPML Cast Iron Pump less Motor	CPML15K-CSQMTV CPML15K-CSBMTV CPML15K-CSFMTV	CPML15
	<u>Vertical Pump End Kit*</u> : Includes CPML Stainless Steel Pump less Motor	CPML15K-SSQMTV CPML15K-SSBMTV CPML15K-SSFMTV	CPML15
	<u>Rebuild Kit</u> : Includes: QTY 1: Flex Joint, Rotor, Stator, Mechanical Seal, Bearing, Retaining Ring & Motor Coupling	CPML15K-TQS CPML15K-TBS CPML15K-TFS	CPML15
	<u>Rebuild Kit</u> : Includes: QTY 1: Flex Joint, Rotor, Stator, Mechanical Seal-Abrasive Resistant, Bearing, Retaining Ring & Motor Coupling	CPML15K-TQS A/R CPML15K-TBS A/R CPML15K-TFS A/R	CPML15
	<u>Bolt Kit</u> : Includes Qty 8: Pump Body Bolts, Washers & Nuts. Qty 4: C-Face Motor Bolts & Washers. Qty 1: 1/8" NPT Drain Plug	U10-15MC	CPML15

* New Housing Configuration includes Bearing and Retaining Ring. Abrasive Resistant Seal is also available, contact us
 Pump End Kit requires no assembly and will bolt to any 56 C-Face Motor with feet.
 This Kit is issued with a Pump Tag and Serial Number.

Continental Pump Company

29425 State Hwy B | Warrenton, Missouri 63383 | Tel: 636-456-6006 | Fax: 636-456-4337 | Email: sales@con-pump.com
 Visit us at: www.continentalultrapumps.com



Materials of Construction

All Continental Pump casting materials are Class 40# grey cast iron and CF8M (316) stainless steel. The best metal for your application would depend on how corrosive your liquid is. We offer an epoxy coating for an additional charge and can be applied to the suction housing and discharge. The epoxy seals the cast iron from the material being pumped.

Stators are available in 3 types of elastomers. The rubber materials are: Buna Nitrile, EPDM and Viton®. The rubber that is best for your application depends on what liquid you are pumping and at what temperature, as it plays a vital role in which to select.

The rotors are available in Chrome Plated Stainless Steel.

Abrasive Resistance Mechanical Seals are a great upgrade for your more abrasive applications. By adding a Stator Barrier, which is recommended in any negative suction and/or vacuum application to help protect the stator. There are lots of variables to take in consideration to know if this is right for your application. Contact us with your application information to see if this is for you.

Looking for simplicity? We offer complete Progressive Cavity Pump Units. They are constructed on a steel base to fit your specific application needs. The Unit consists of a Pump, a Steel Base & Guard, a Gear Reducer and Motor. Also available are Belt Drive Units, Gas or Diesel Engines, and many other base options.

Space Challenged? If you are needing a different arrangement from traditional piping, we have vertical suction housings available in the CP Model.

Don't need a complete pumping unit but looking for drive options? We can still help, whether attached to a pump or sold separately we can supply you with VFD's, Motors and Bases.

Continental Pump Company

29425 State Hwy B | Warrenton, Missouri 63383 | Tel: 636-456-6006 | Fax: 636-456-4337 | Email: sales@con-pump.com
Visit us at: www.continentalultrapumps.com